

Replacement Parts for Aluminum 8" & 12" Signals and Beacons

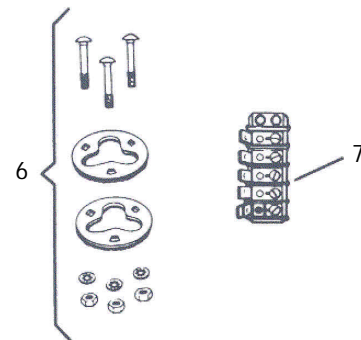

Section connectors and terminal block

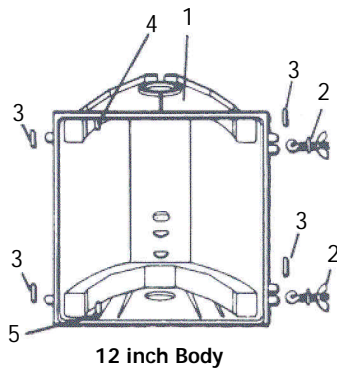
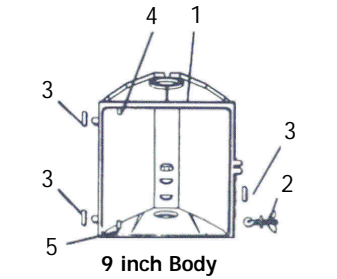
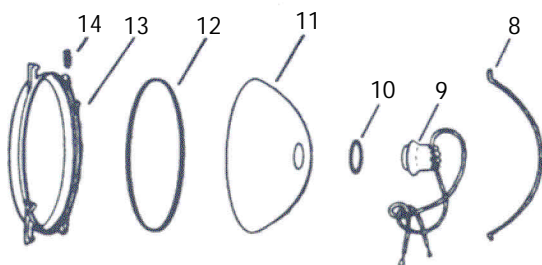

Bulb receptacle and reflector parts

Ordering Information

Parts for 8" (200mm) & 12" (300mm) Aluminum Signals and Beacons

Item	Part Description	Catalog Number	
		8-inch	12-inch
1	Body*.....	0700005	0700006
2	Eye bolt, wing nut, and washer assembly	TL4119	TL4119
3	3/16" x 1" medium spiral pin for eye bolt and door	11C12-018D32	11C12-018D32
4	Groove pin, top.....	11C02-018D24	11C02-018D24
5	Broove pin, bottom	11C02-018D16	11C02-018D16
6	Bolt assembly for connecting sections.....	0700127	0700127
7	Terminal block, 5 position	20U14-005	20U30-005
8	Spring wire bail.....	0700011	0700012
9	Receptacle and lead assembly, black and white wires	0700620B	0700620B
	Receptacle and lead assembly, red and white wires	0700620R	0700620R
	Receptacle and lead assembly, yellow and white wires.....	0700620Y	0700620Y
	Receptacle and lead assembly, green and white wires.....	0700620G	0700620G
10	Receptacle gasket.....	13B12-1395	13B12-1395
11	Alzak® aluminum reflector assembly.....	0700003	0700004
12	Reflector gasket.....	013G51-1398	013G51-1399
13	Reflector retaining ring	0700454	0700455
14	Reflector spring	0700013	0700013

* Standard colors are Dark Green and Federal Yellow.
Please specify color on the order.

Ordering Information

Additional Parts for 8 & 12-inch Aluminum Signals and Beacons

Item	Part Description	Catalog Number	
		8-inch	12-inch
15	Door only*	0700007	0700008
16	Door gasket	0700477-8	0700477-12
17	Lens	See Visors and Lenses sheet for listing	
18	Lens gasket.....	0700474	0700473
19	Lens clip	0700014	0700014
20	Lens clip screw	10A08-019D08	10A08-019D08
21-24	Visors.....	See Visors and Lenses sheet for listing	

* Standard colors are Dark Green and Federal Yellow.
Please specify color on the order.

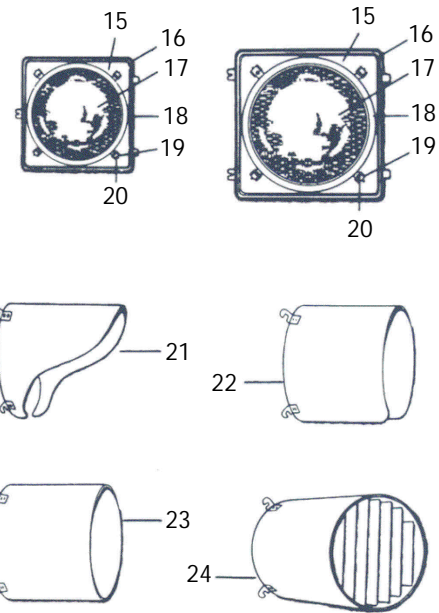

Making the World a Safer Place to Travel™

<http://www.peek-traffic.com>

Please contact Peek Traffic Corporation for customer inquiries about any of the company's Traffic Control, Data Collection, Enforcement, Detection, or Tolling products. To learn how Peek Traffic is making the world a safer place to travel, visit the Peek Traffic web site at <http://www.peek-traffic.com>.

The information contained in this publication is presented for informational purposes only, and while every effort has been made to ensure its accuracy, the information is not to be construed as warranties or guarantees, express or implied, regarding the products or services described herein or their use or applicability. No license is granted by implication or otherwise to any of Peek Traffic's intellectual property. Peek Traffic reserves the right to alter or revise any of its products or published technical data relating thereto at any time without notice.

Copyright © 2004 Peek Traffic Corporation, A Quixote Company. All rights reserved. Printed in the United States.

Peek Traffic Corporation

A Quixote Company
2511 Corporate Way
Palmetto, Florida 34221
phone: (941) 845-1200
toll free in the US: 1 (866) 260-7335
fax: 1 (941) 365-0837